

TORINO WRAPPING

EN new generation of European pallet wrapper, the ideal solution for wrapping your pallets budget friendly

FR nouvelle génération de banderoleuse européenne, la solution économique idéale pour banderoler vos palettes

NL nieuwe generatie Europese palletwikkelaar, de ideale oplossing voor kwalitatief en budgetvriendelijk wikkelen van pallets

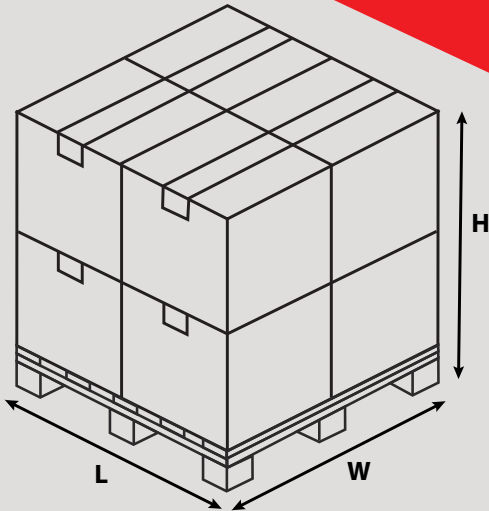

(mm)	max
L	1200
W	1000
H	2200

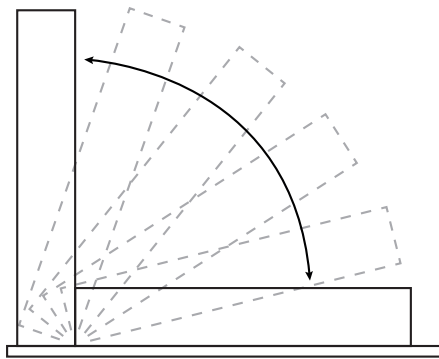

EN extremely easy to install and move thanks to fork slots in the bottom frame and a pivoting column

FR extrêmement facile à installer et déplacer grâce aux ouvertures pour fourches et colonne pivotante

NL uiterst eenvoudig te (ver)plaatsen en installeren dankzij vorkgleuven en scharnierend opgestelde kolom

DETAILS / DÉTAILS

foliesledes - dévidoirs - foil carriers

T2.0

mechanical adjustable brake

frein à régulation mécanique

mechanische regelbare rem

T2.5

electrically adjustable brake

frein à régulation électronique

elektronische regelbare rem

T3.0

easy load powerstretch system

système de pré-étirage facile à charger

easy load powerstretch systeem

MADE IN EUROPE

Economical packaging solutions of uncompromising European quality



 **plug 'n pack**



EN End-of-line packaging specialist with over 40 years experience. Coeman is the logistics & technical partner for packaging machinery.

FR Spécialiste en emballages de fin de ligne depuis plus de 40 ans. Coeman est le partenaire technique et logistique de machines d'emballage par excellence.

NL End-of-line verpakkingsspecialist met meer dan 40 jaar ervaring. Coeman is dé logistieke en technische partner voor verpakkingsmachines.

INNOVATION PREMIUM LINE PROJECTS



Coeman Packaging NV

Textielstraat 17 - 8790 Waregem
T +32 (0)56 77 56 81 - E info@coeman.be
www.coeman.be